

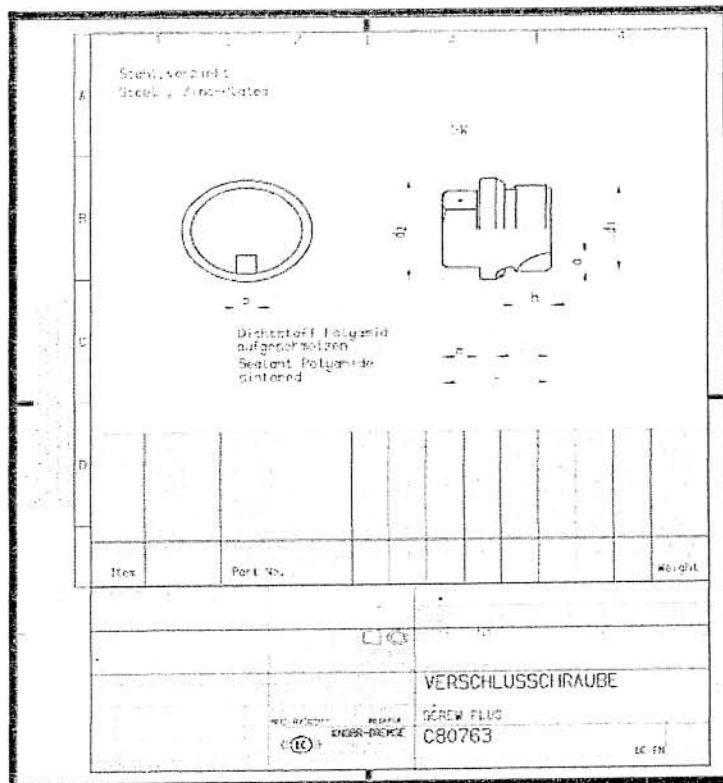

D51 Perno

0044

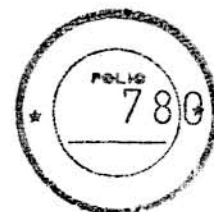

D52 Unidad de control auxiliar

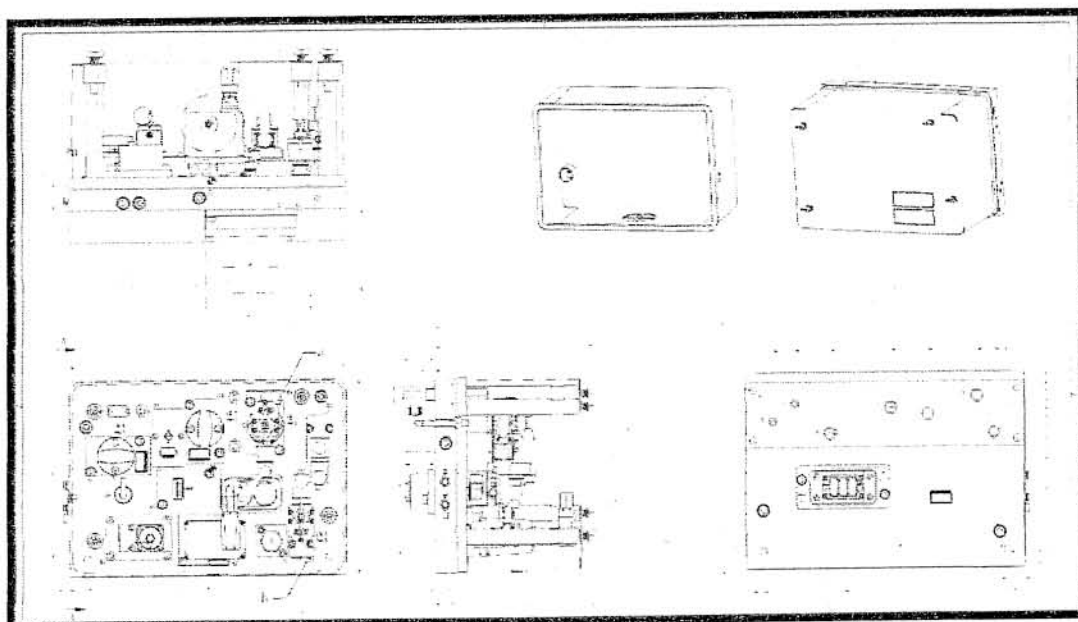

D53 Silenciador

0044

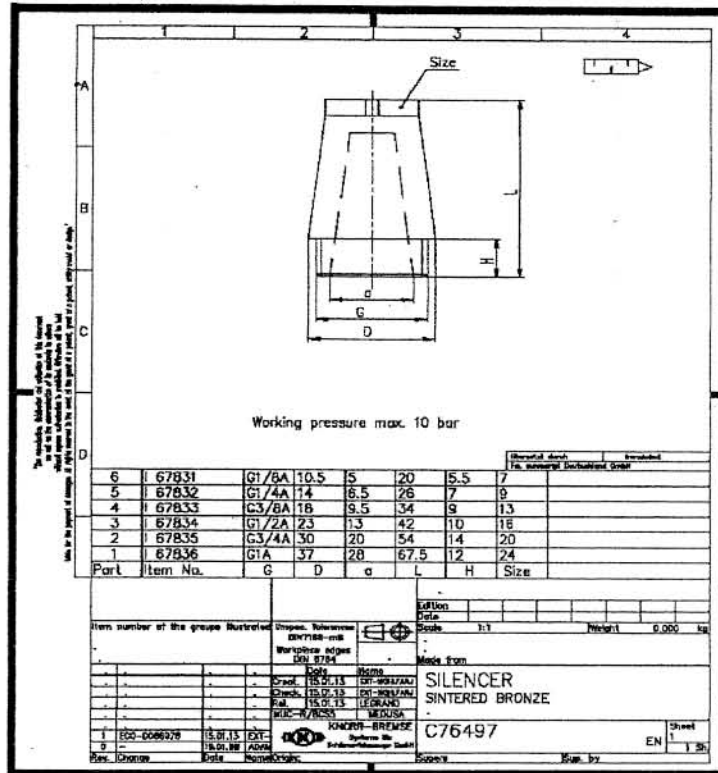
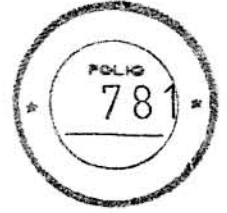

D54 Anillo de sellado

En calibre y calibre doble

D55 Unidad de control de freno

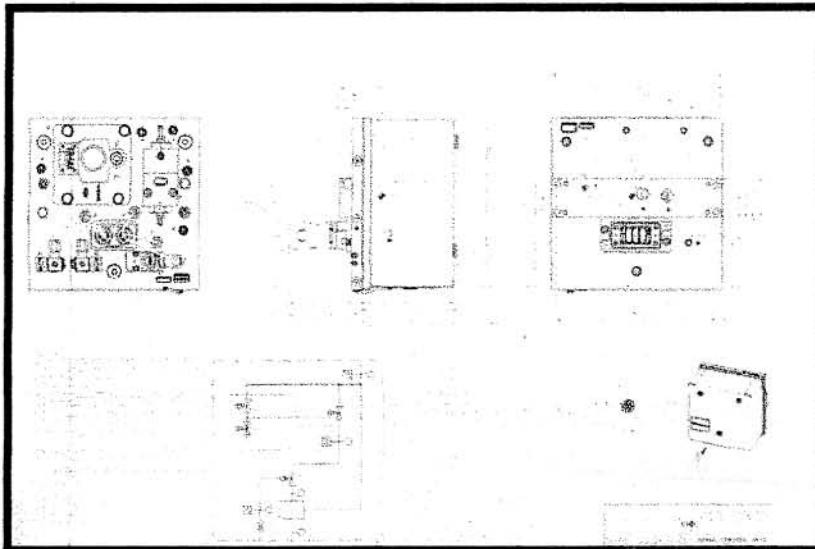



D56 Tubos para manguera de freno de estacionamiento

0044

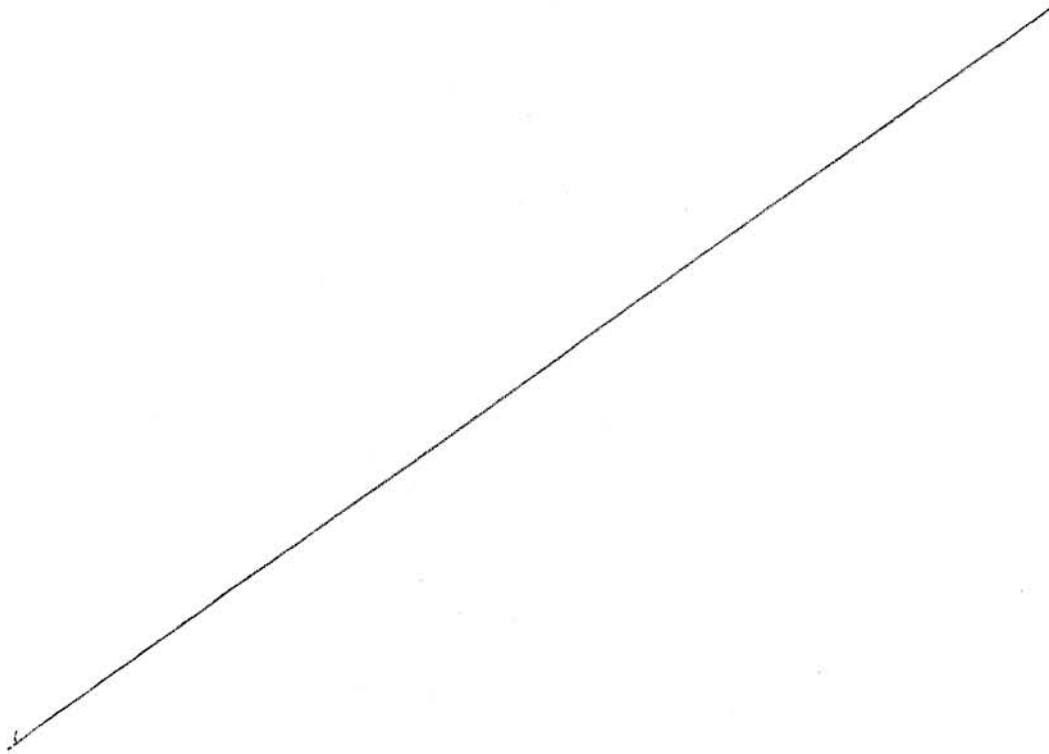
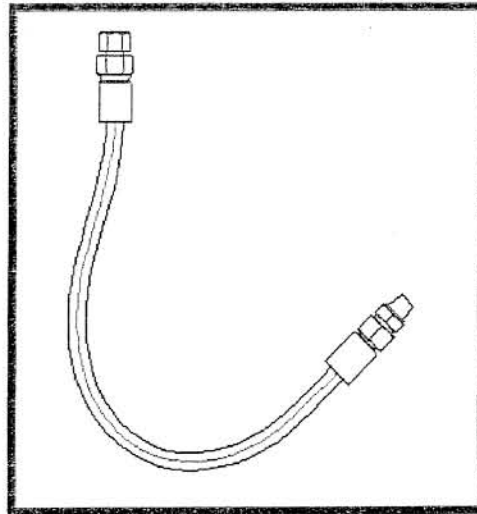

Parte E Sistema HVAC (Calefacción, ventilación y aire acondicionado)

0044

E1 Sistema HVAC completo (King Guangzhou)

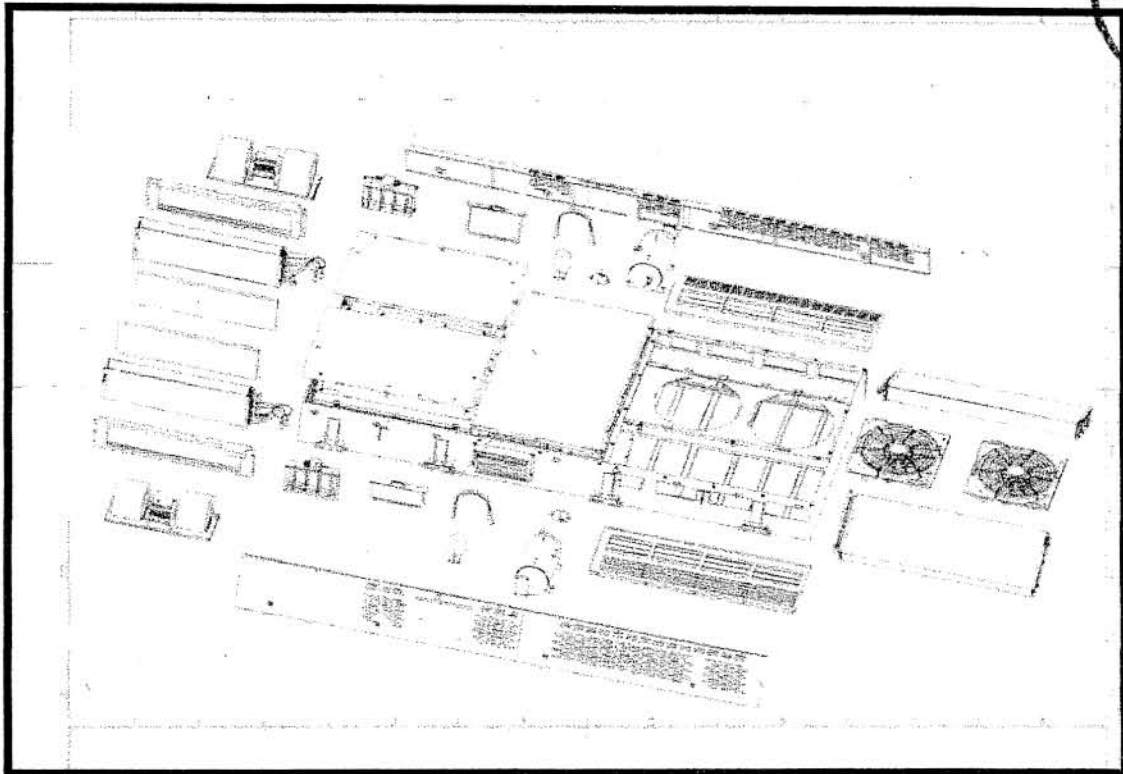
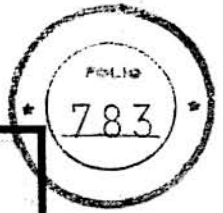

E2 Compresor

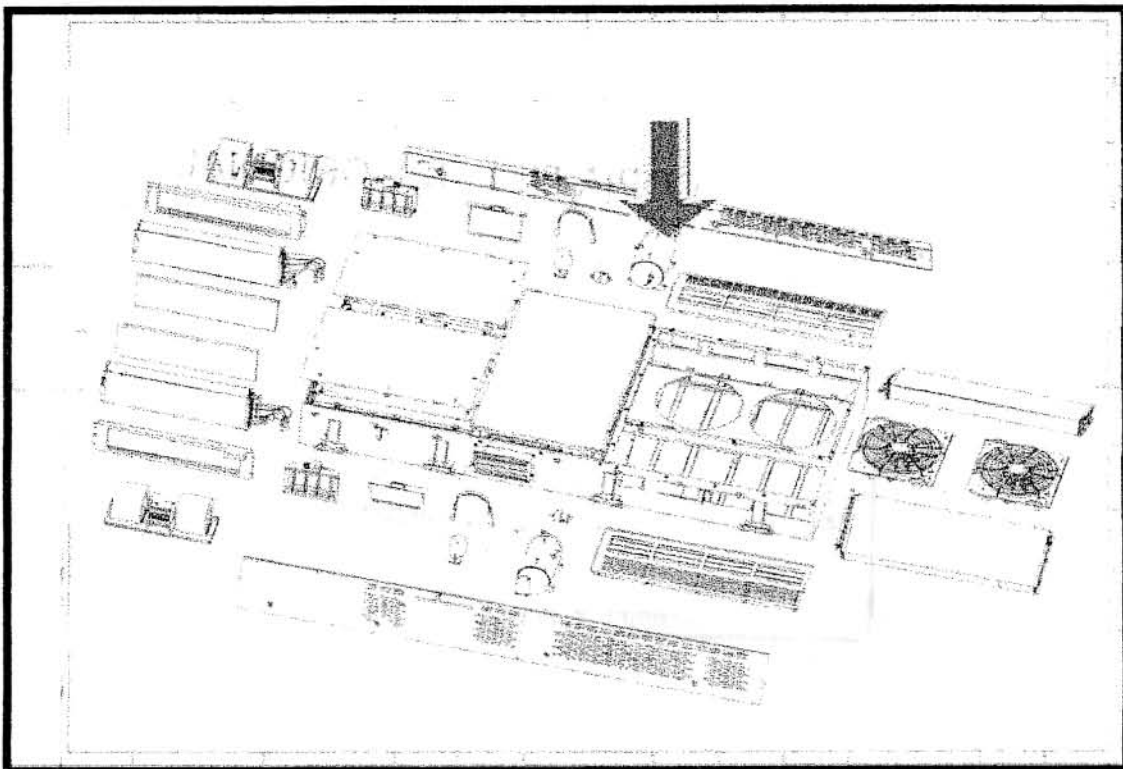

E3 Motor de ventilador del condensador

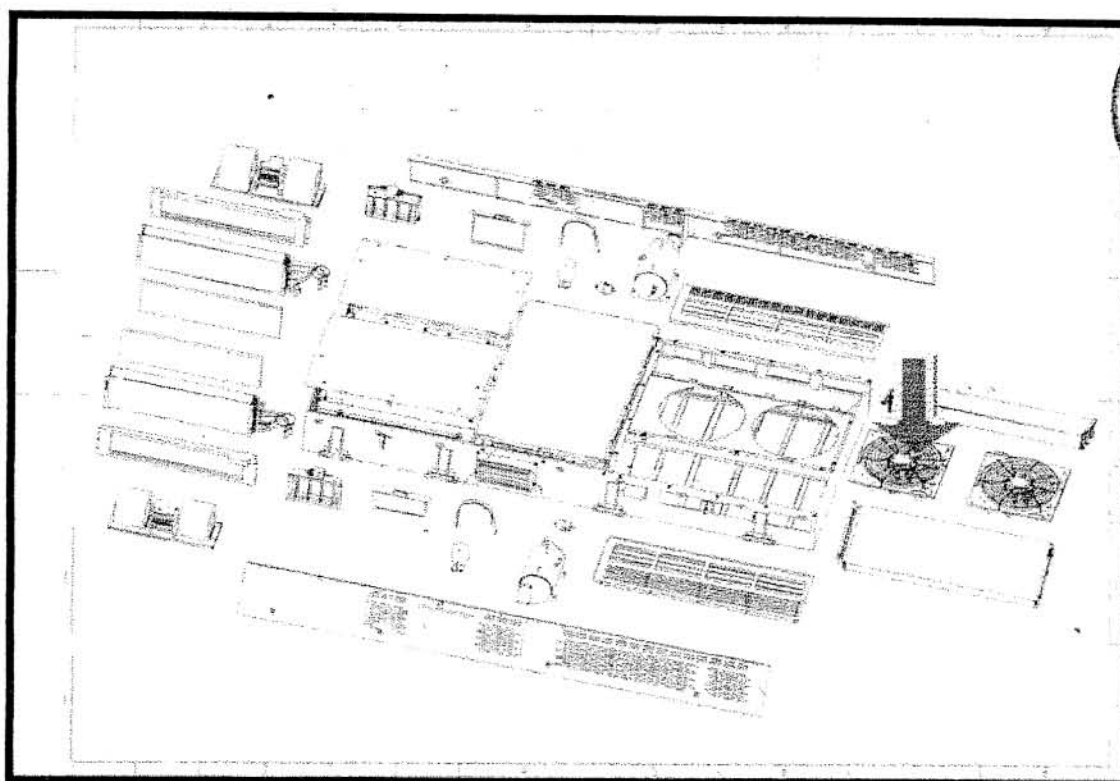
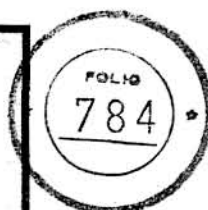

E4 Motor de ventilador del evaporador

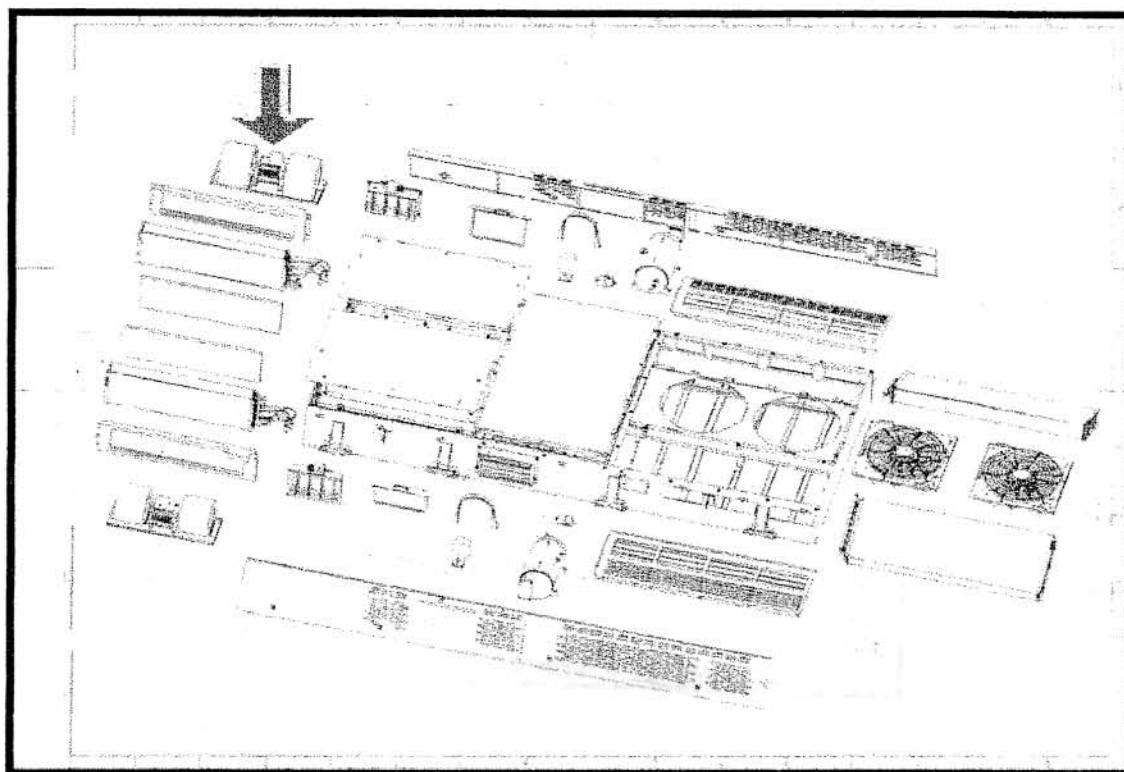

E5 Ventilador del condensador

0044

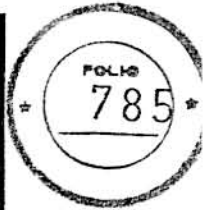
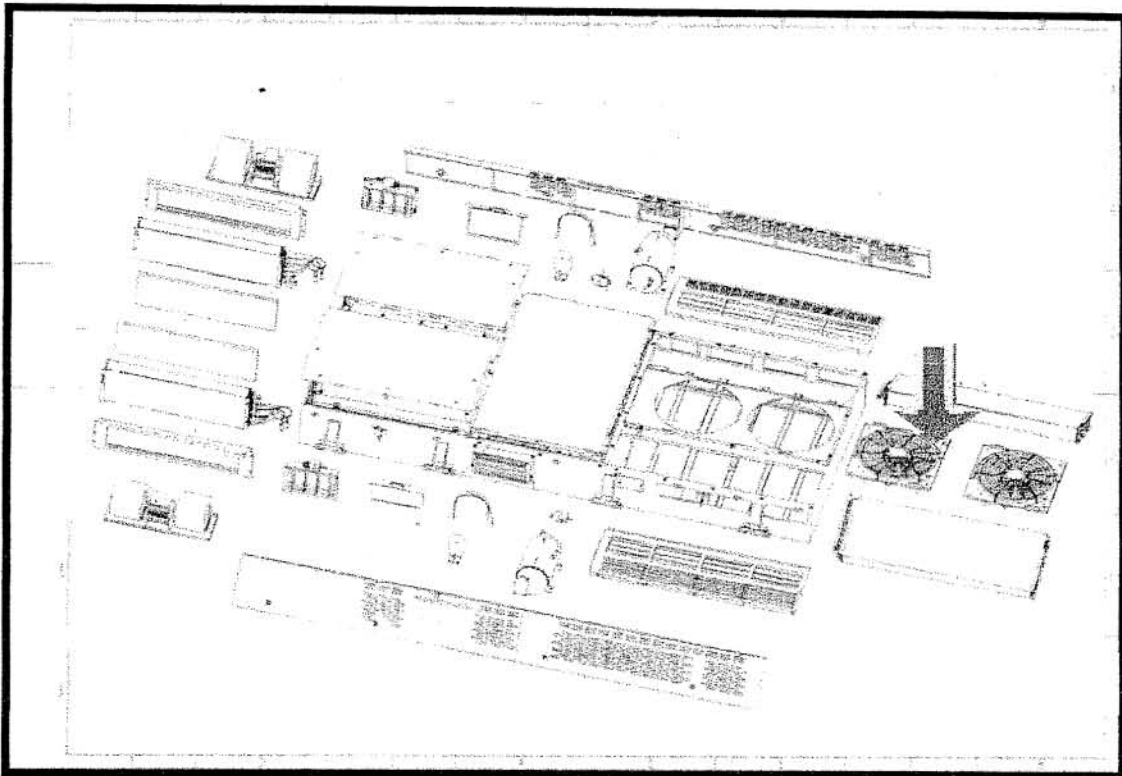

E6 Control de presión dual

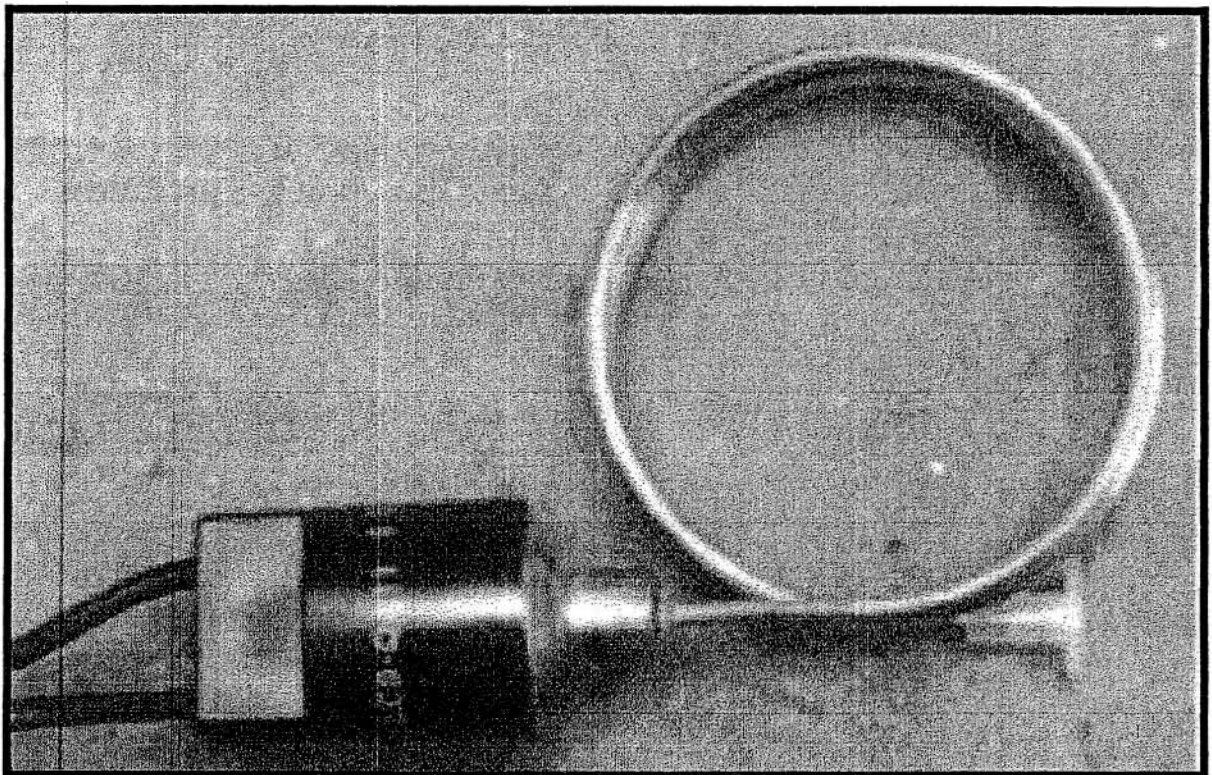

E7 Control de alta presión

0044

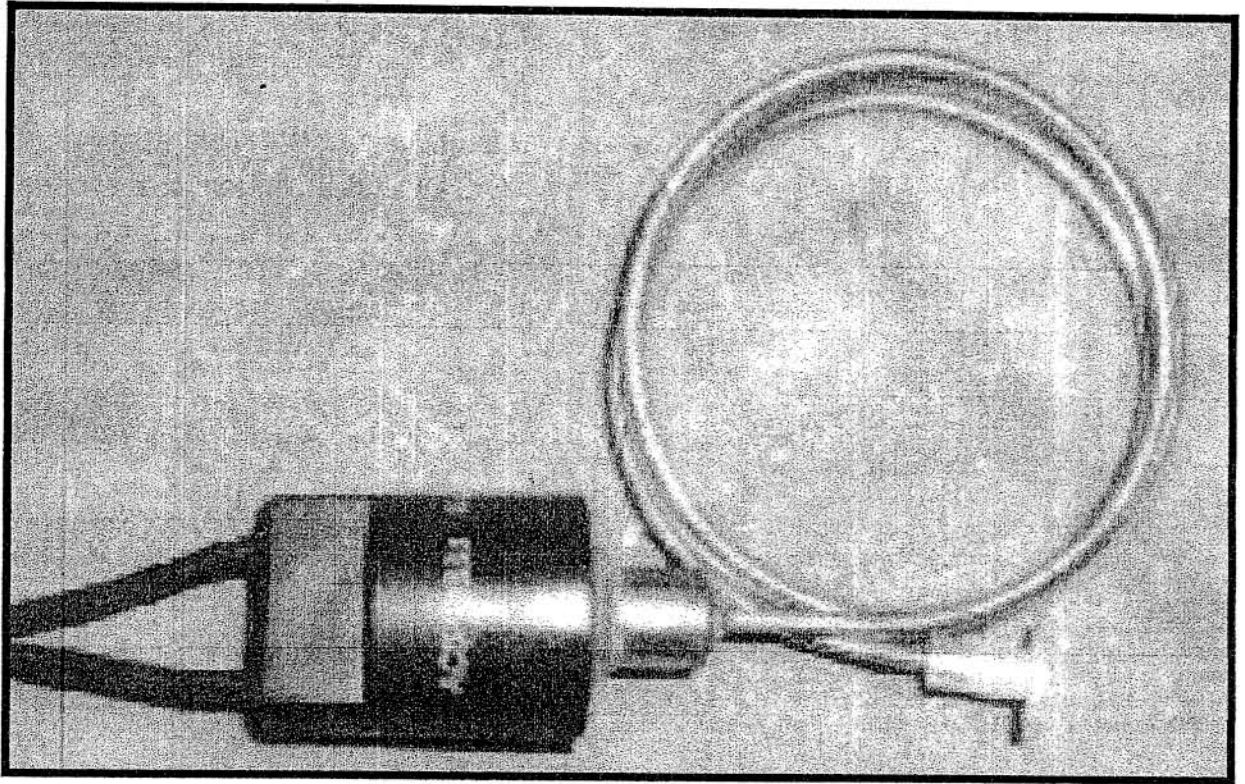

E8 Secador de filtro

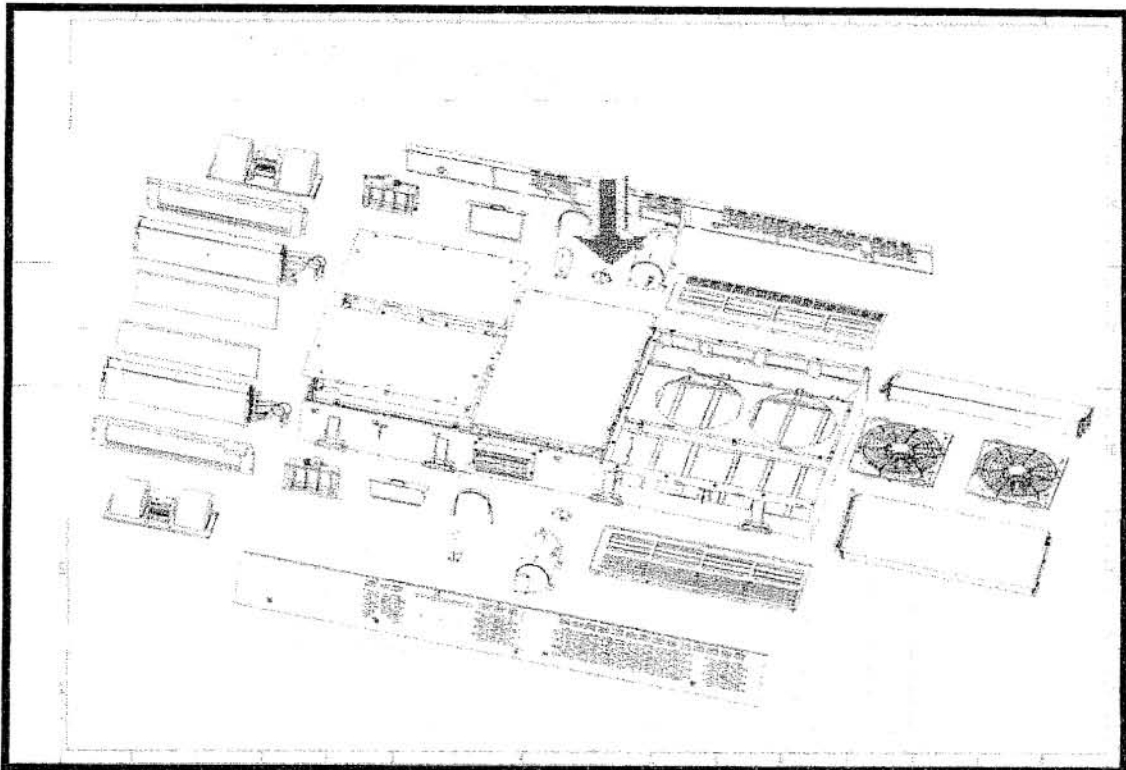

E9 Refrigerante R407C



E10 Sello de aire de suministro

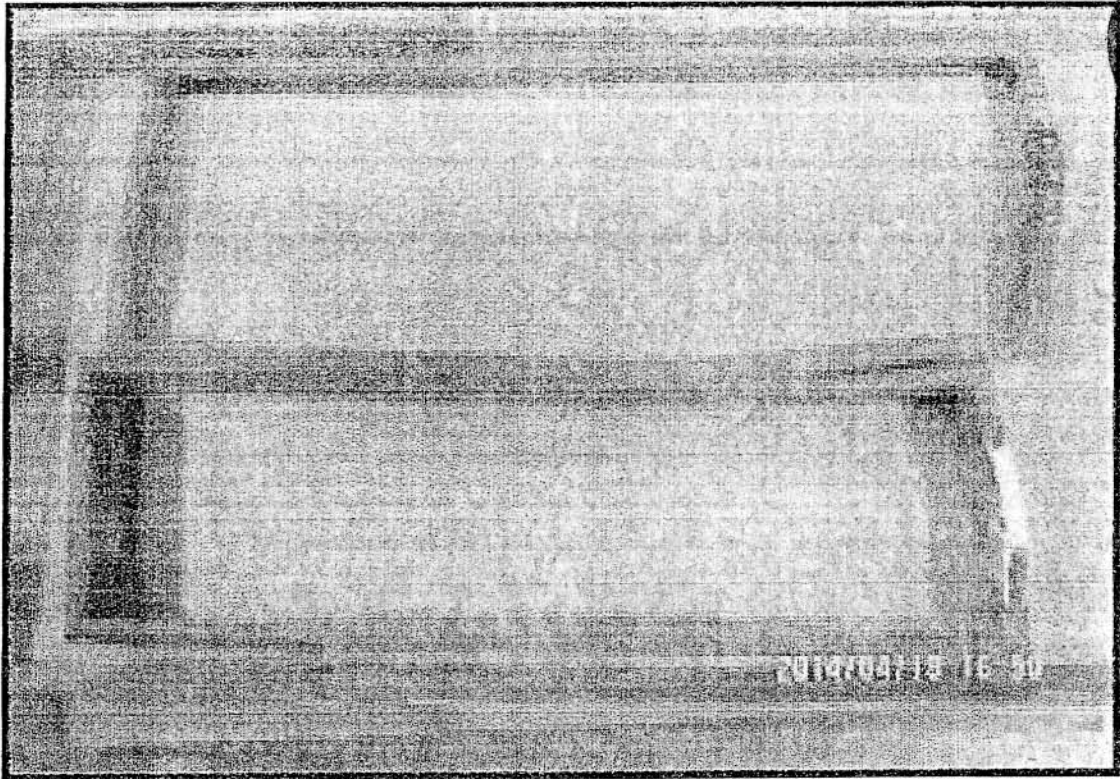
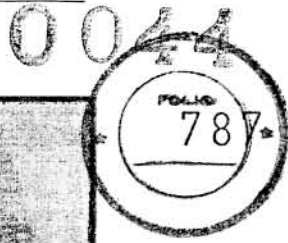

E11 Sello de aire de retorno

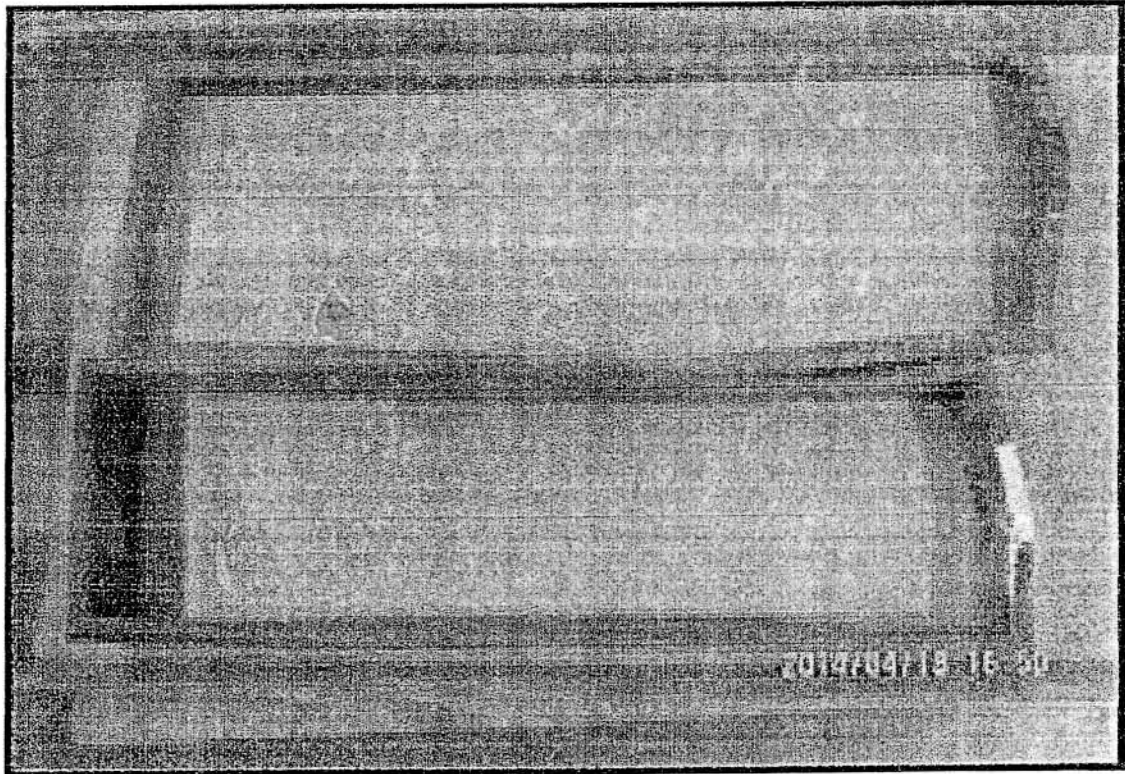

E12 Ventilador de aire de suministro

0044

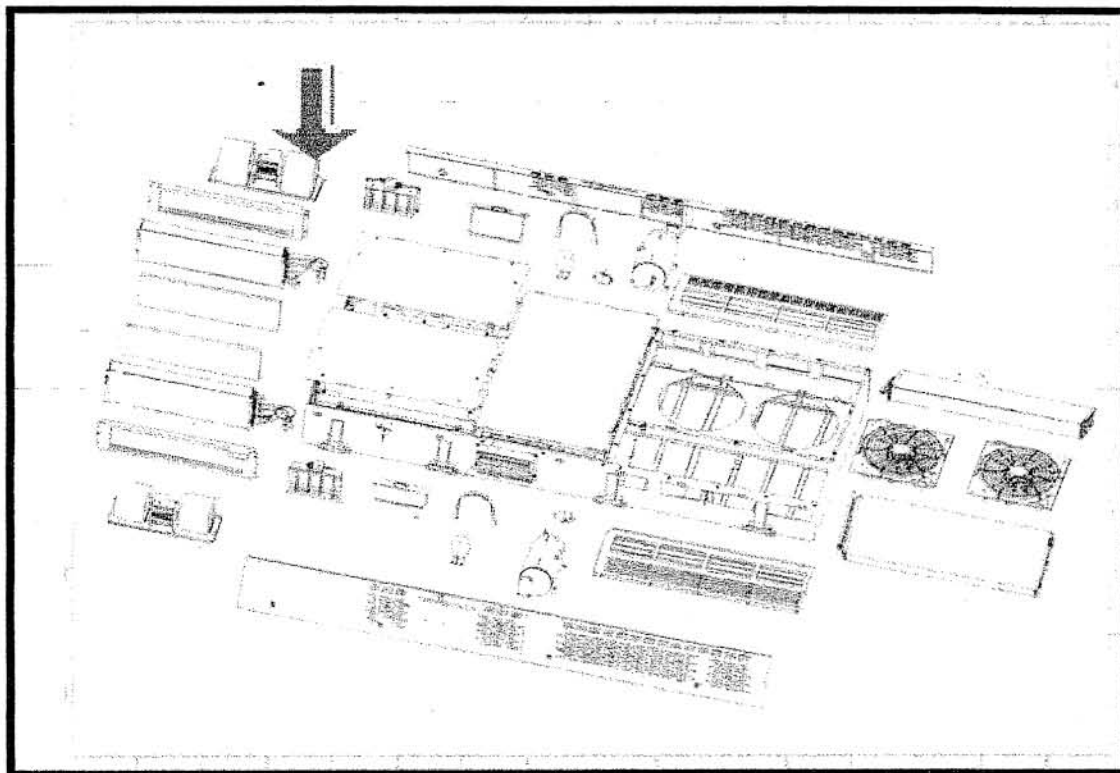

E13 Transformador de 3 etapas (250w)

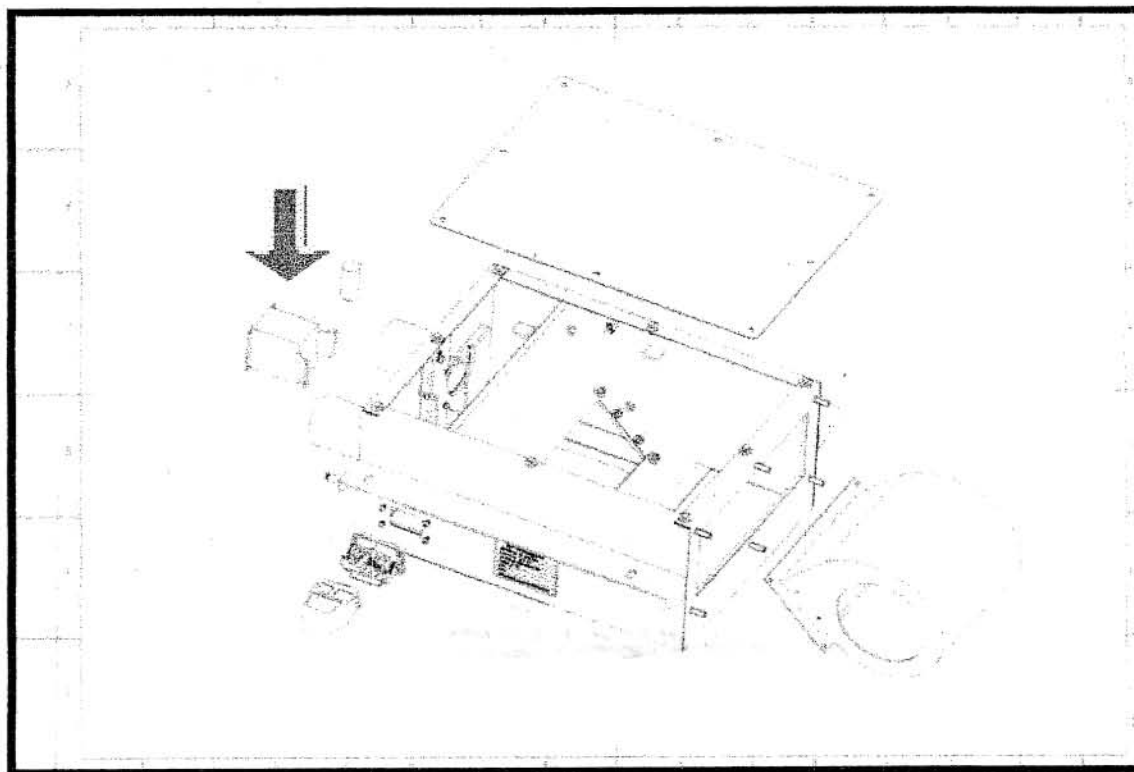



- E14 Cortacircuitos del circuito de ventilación
- E15 Cortacircuitos 2
- E16 Cortacircuitos 3
- E17 Cortacircuitos 4
- E18 Contactor 1
- E19 Contactor 2
- E20 Contactor 3
- E21 Relé
- E22 Relé de falla energética
- E23 Microprocesadora
- E24 Interruptor giratorio

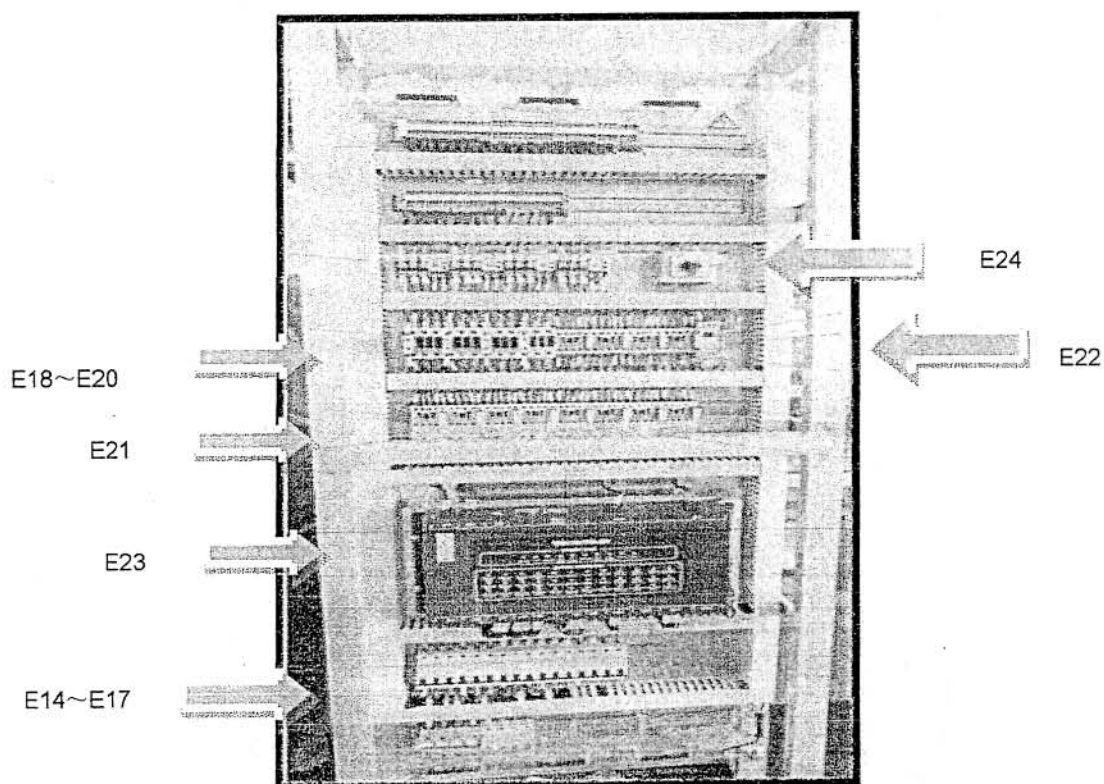
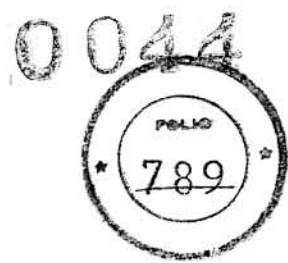



0044

E25 Amortiguador

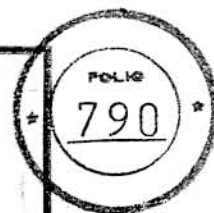
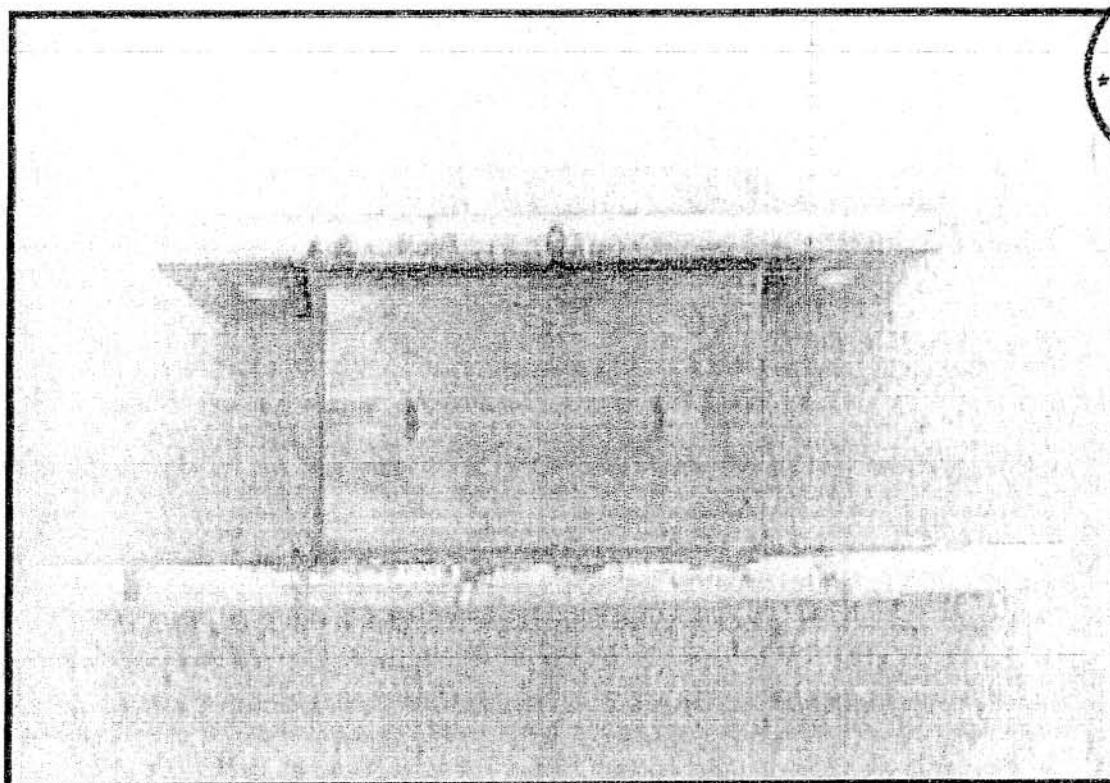

E26 Filtro de succión

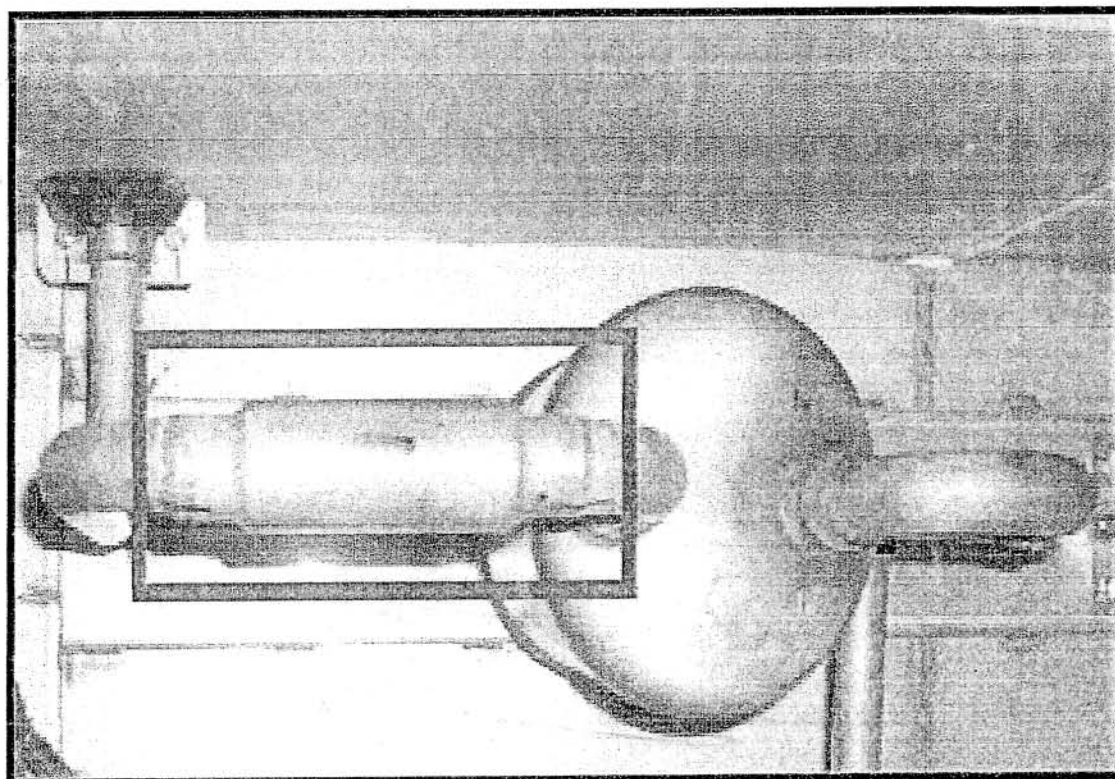



E27 Separador de gases y líquidos

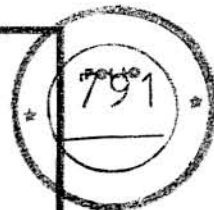
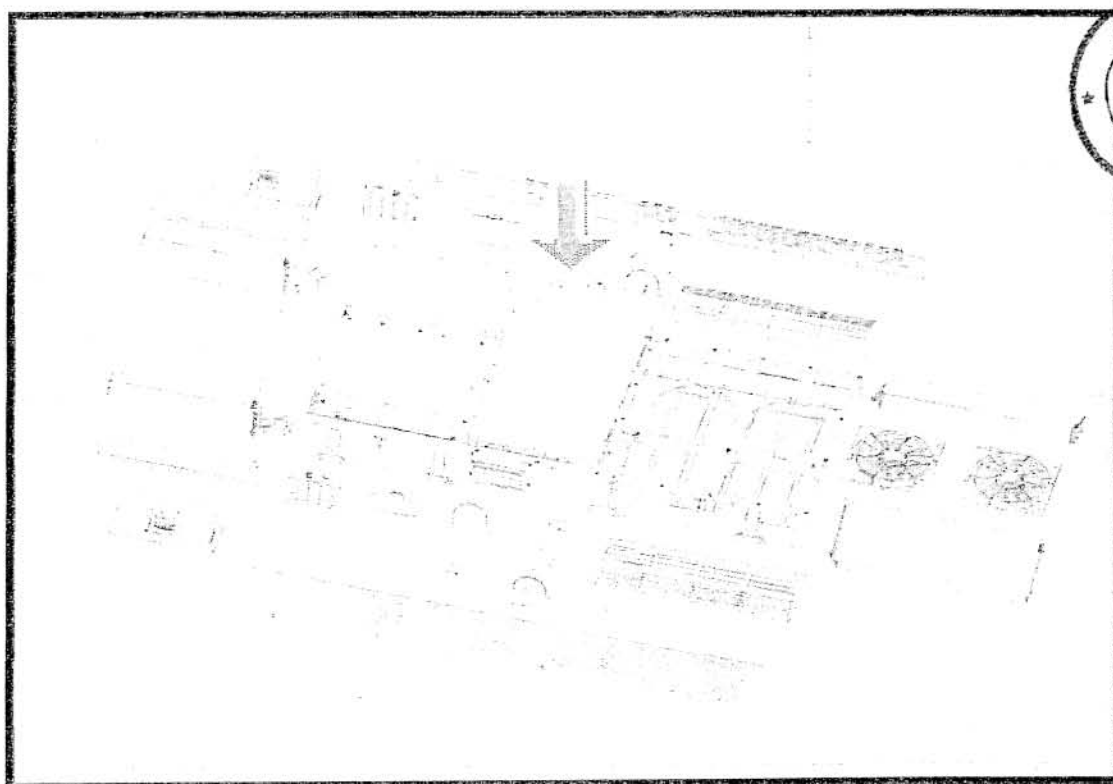

E28 Calefactor eléctrico uno

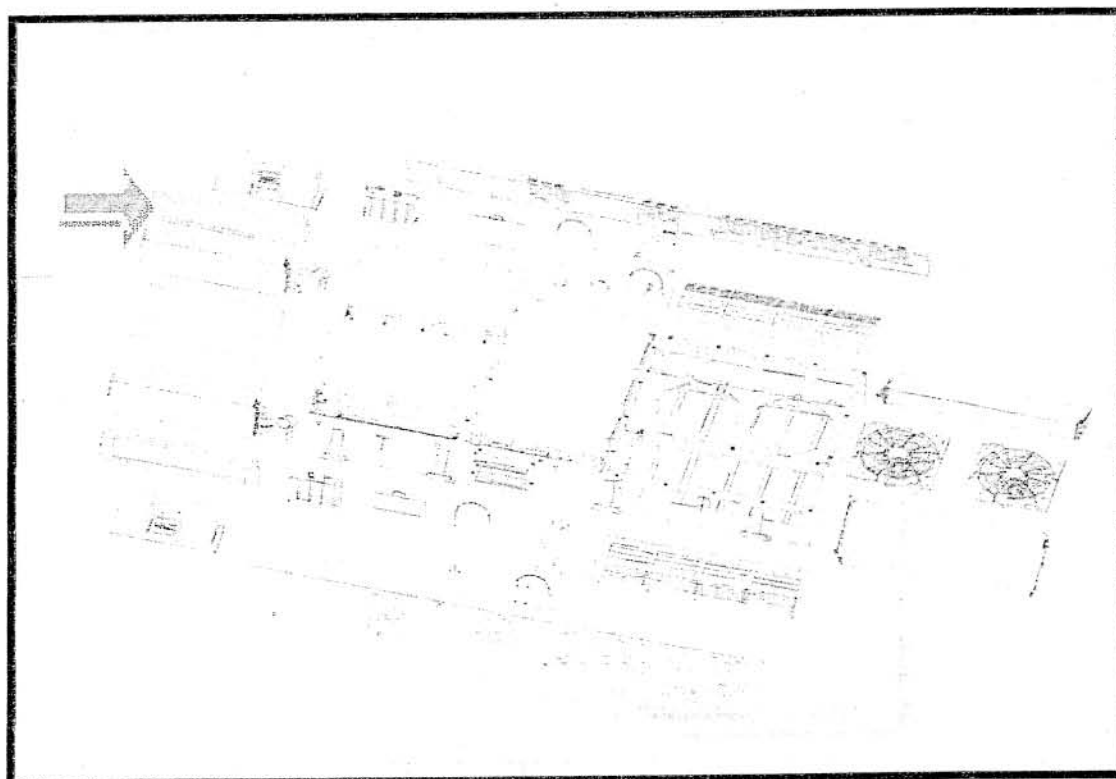



0044
FOLIO
792

E29 Calefactor eléctrico dos

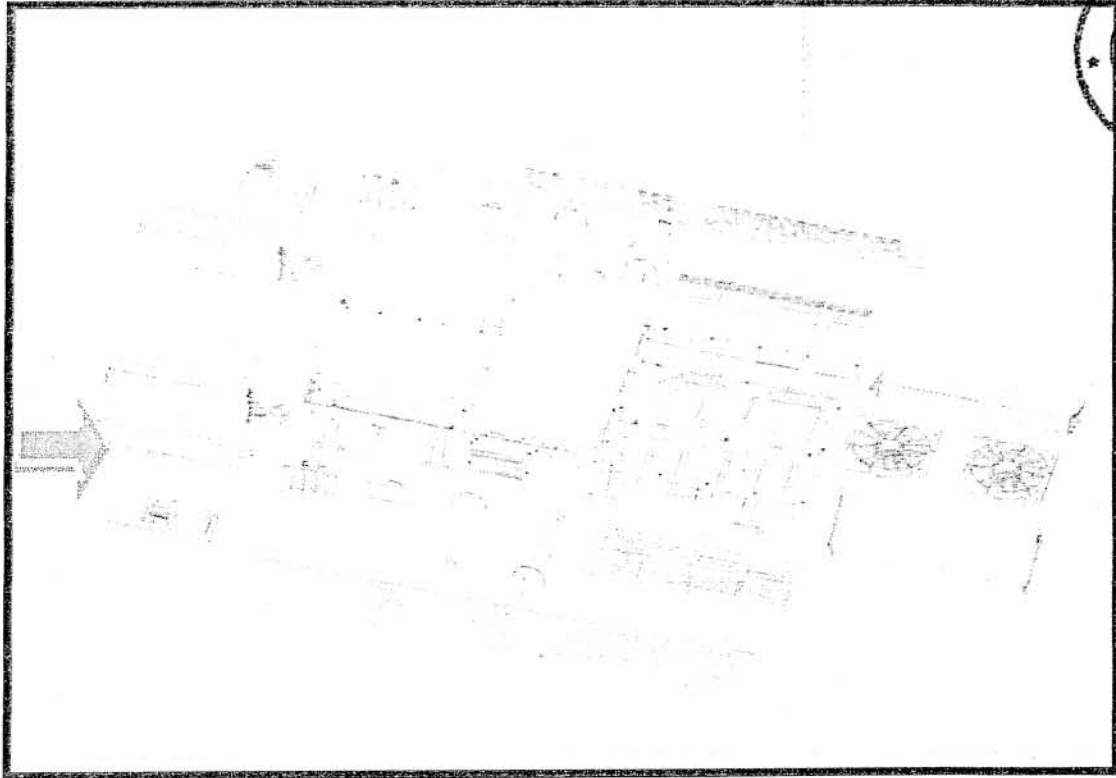

E30 Regulador de aire fresco

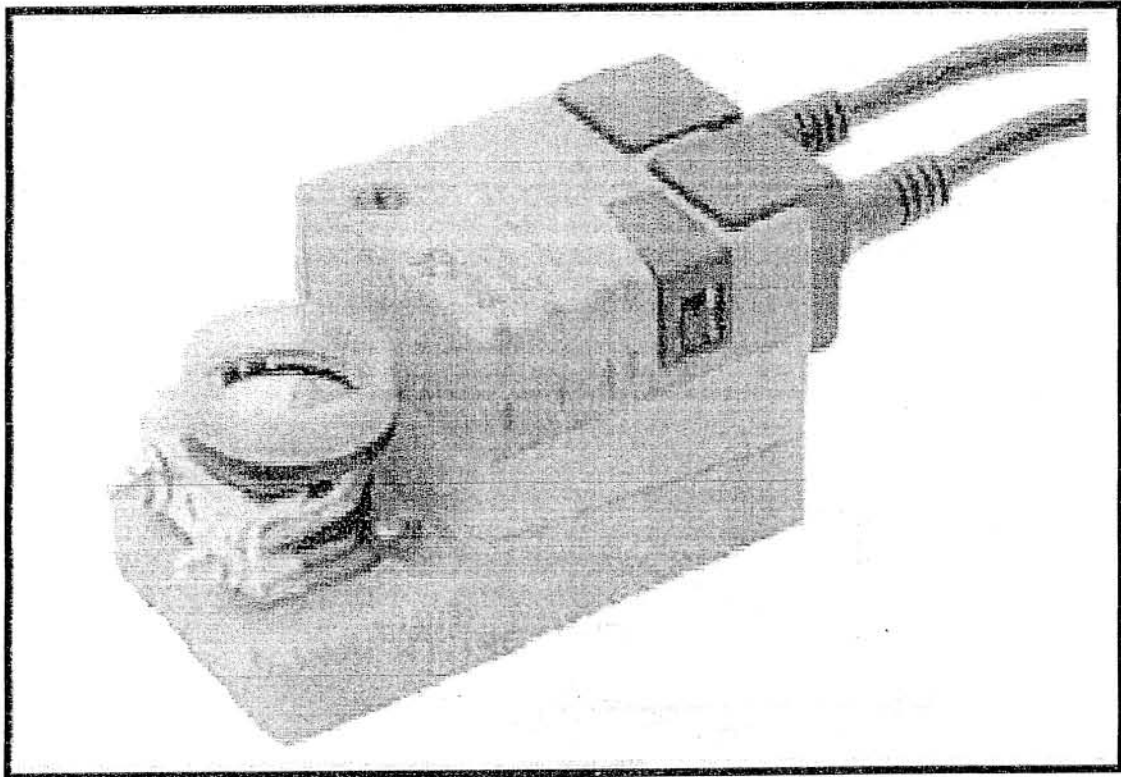



0044

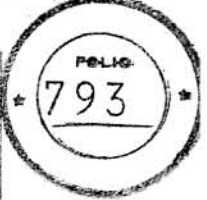

E31 Sensor de temperatura

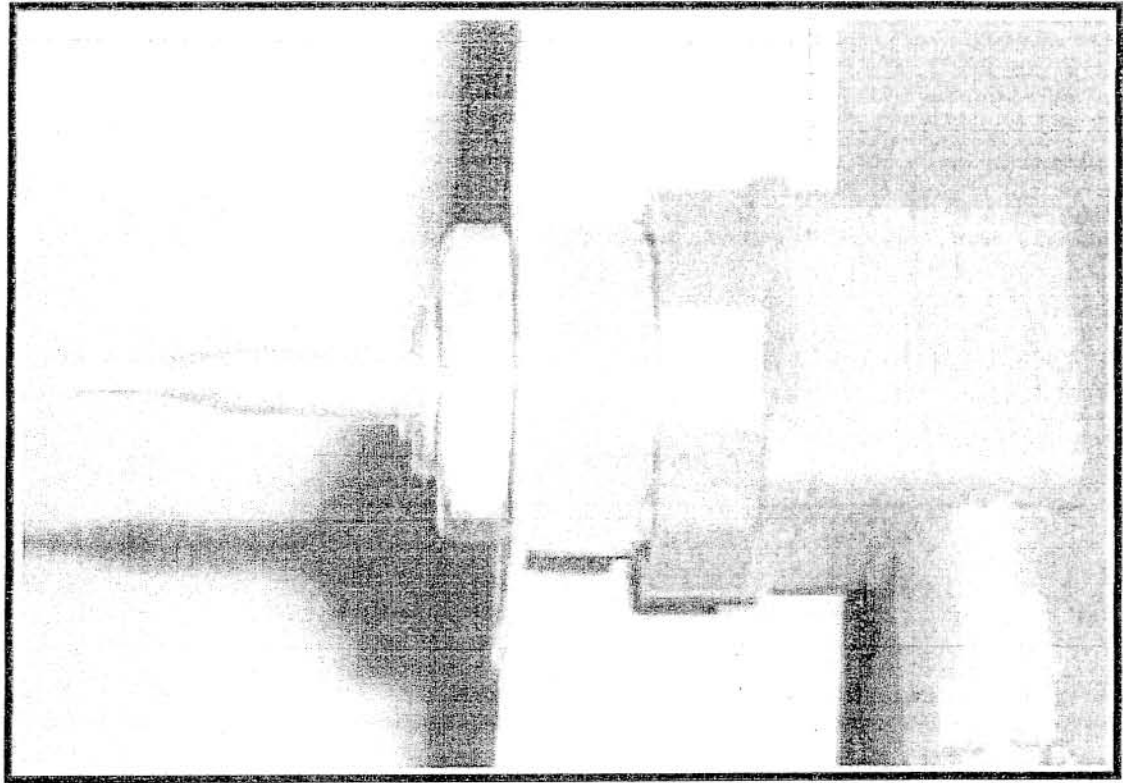

E32 Conector del circuito principal

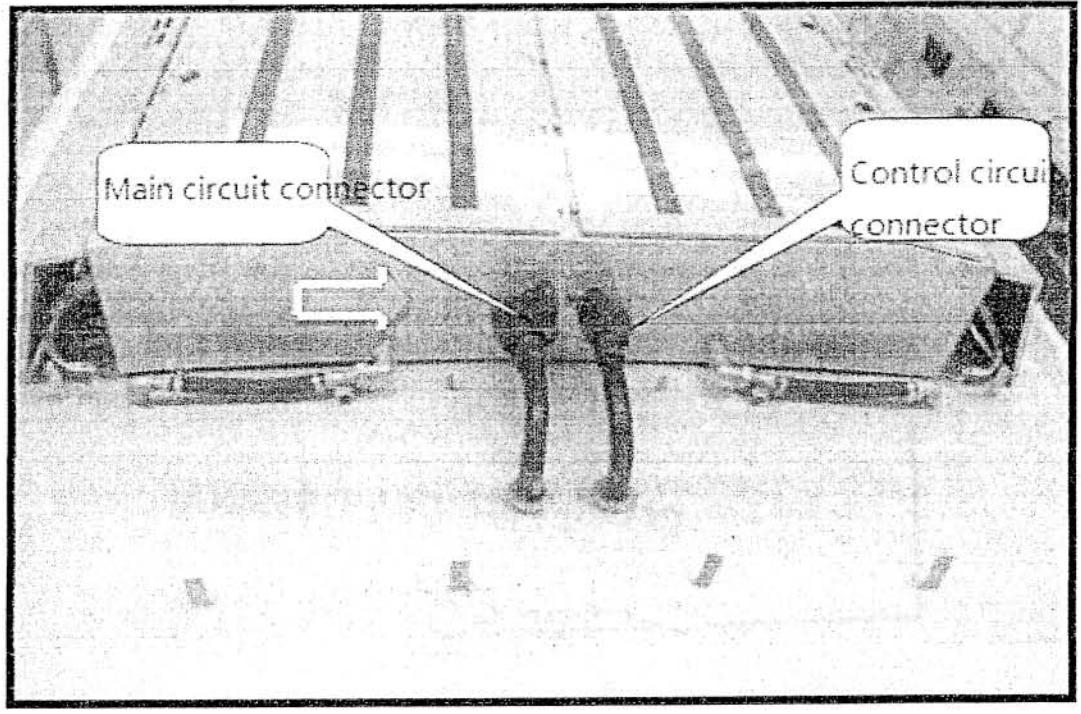

E33 Conector del circuito de control

0044

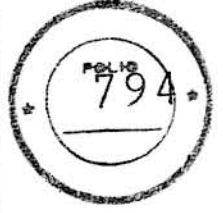
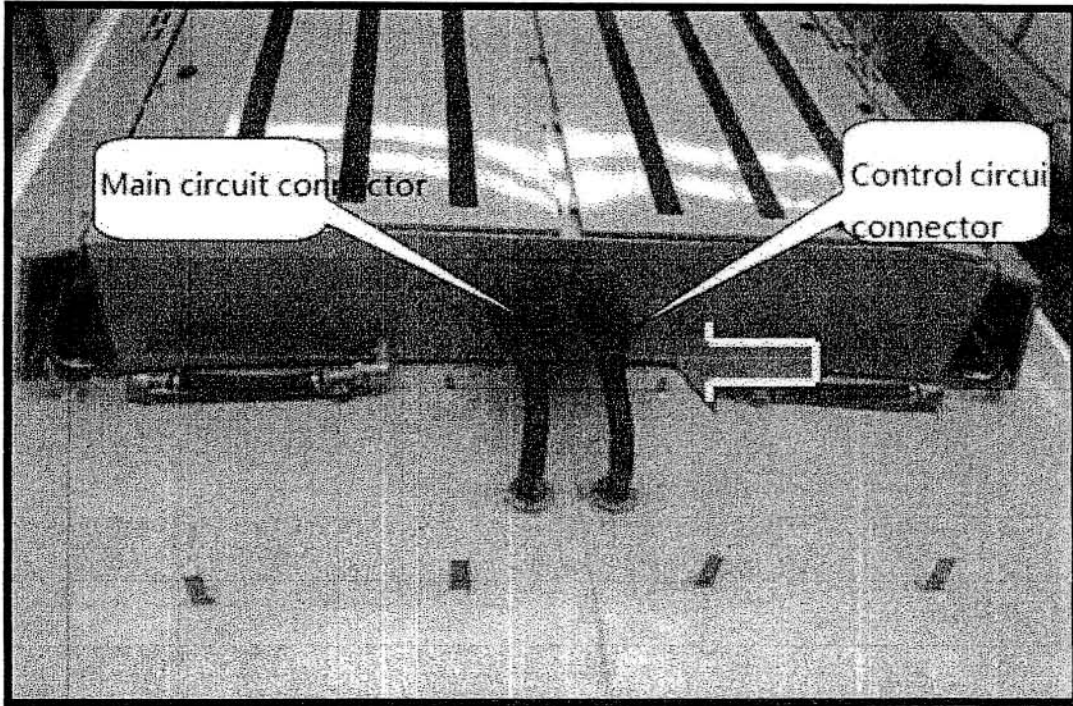

E34 Ventilador de aire de suministro (cabina)

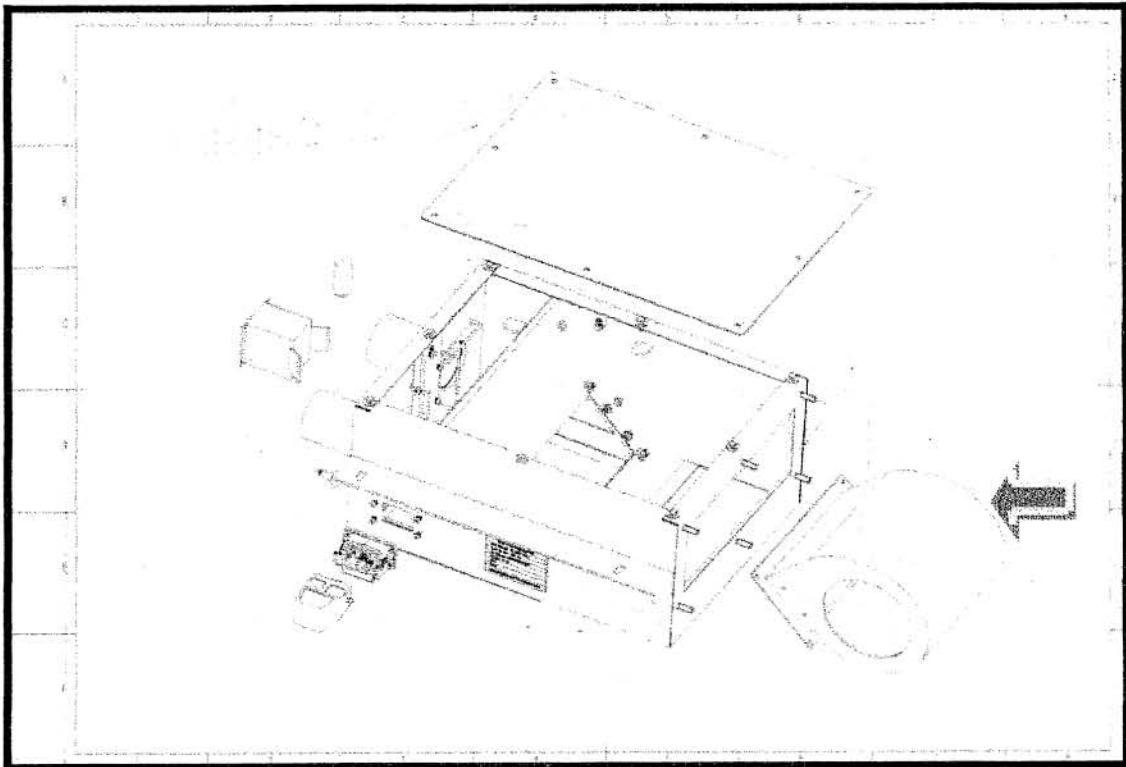

0044

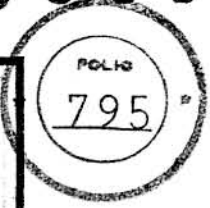

E35 Conector

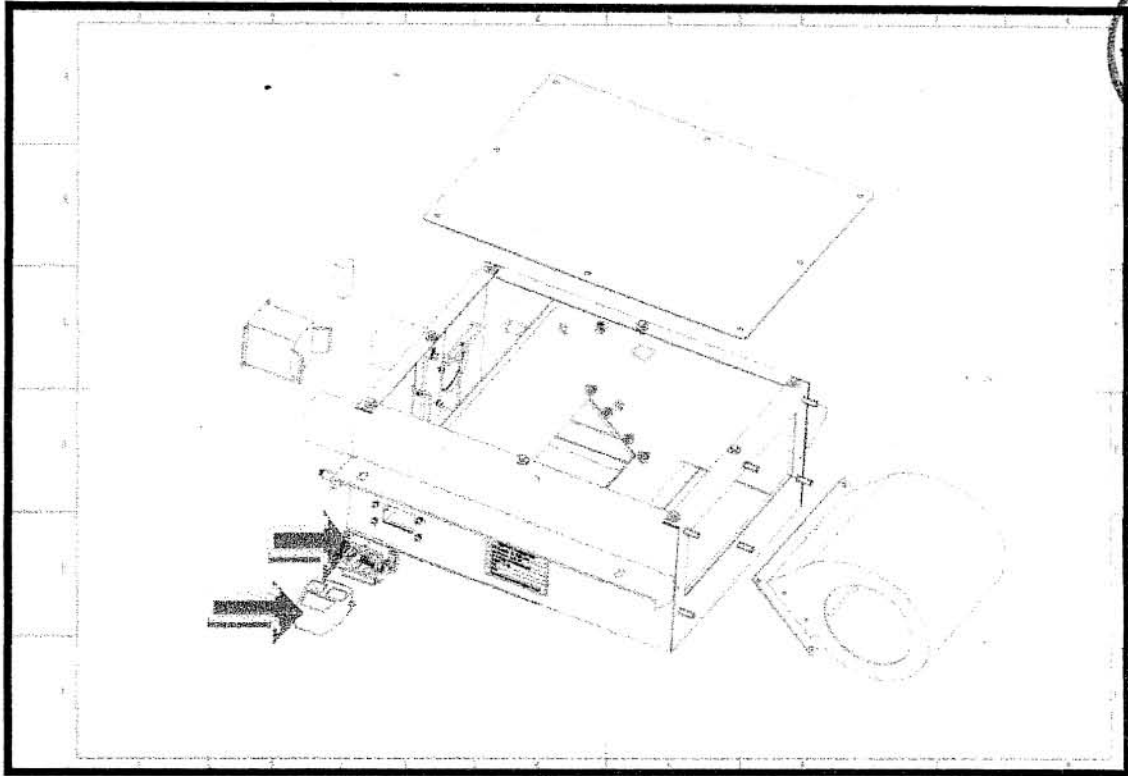

E36 Relé térmico

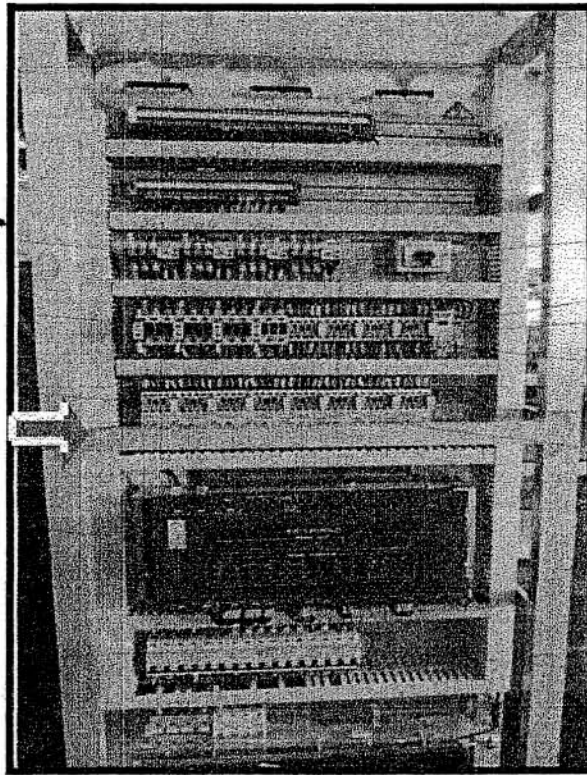



0044

E37 Relé de sobrecarga térmica 2

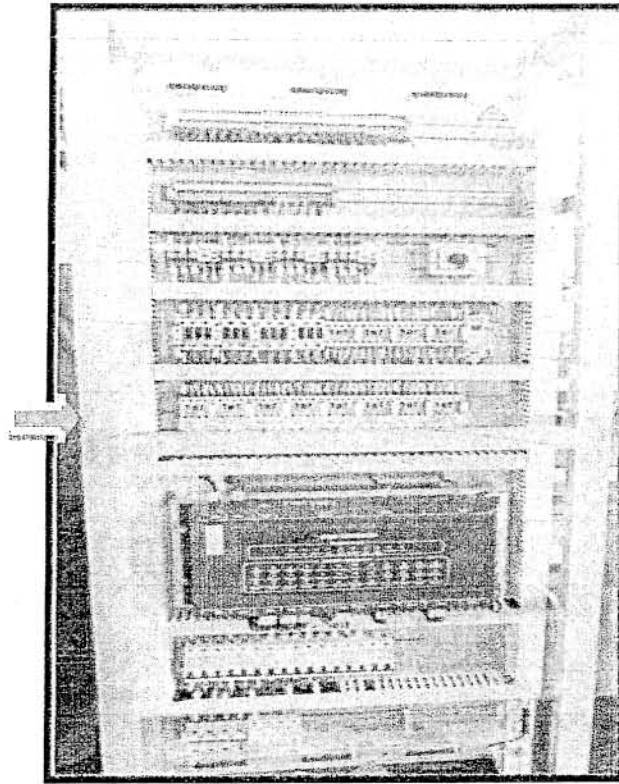
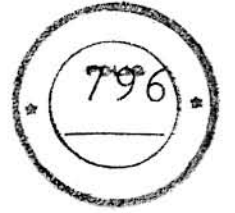

E38 Relé de sobrecarga térmica 3

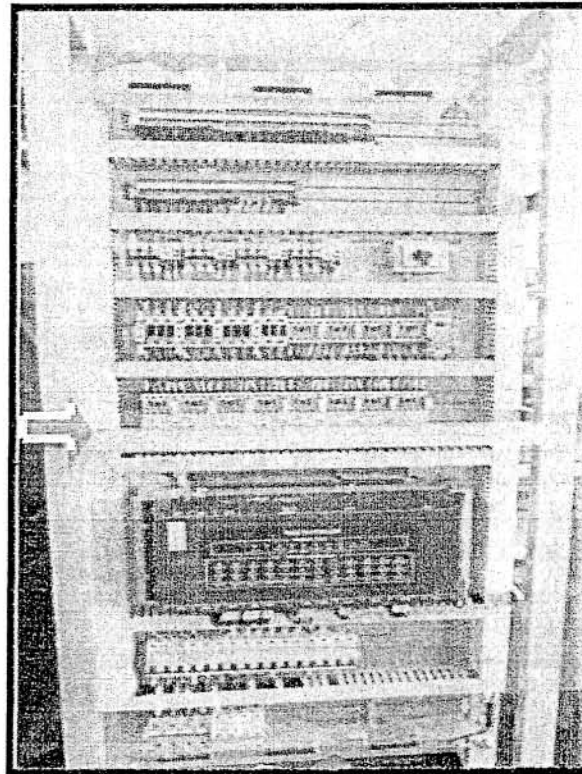



Parte F Bogie

0044

F1 Conjunto de juegos de ruedas

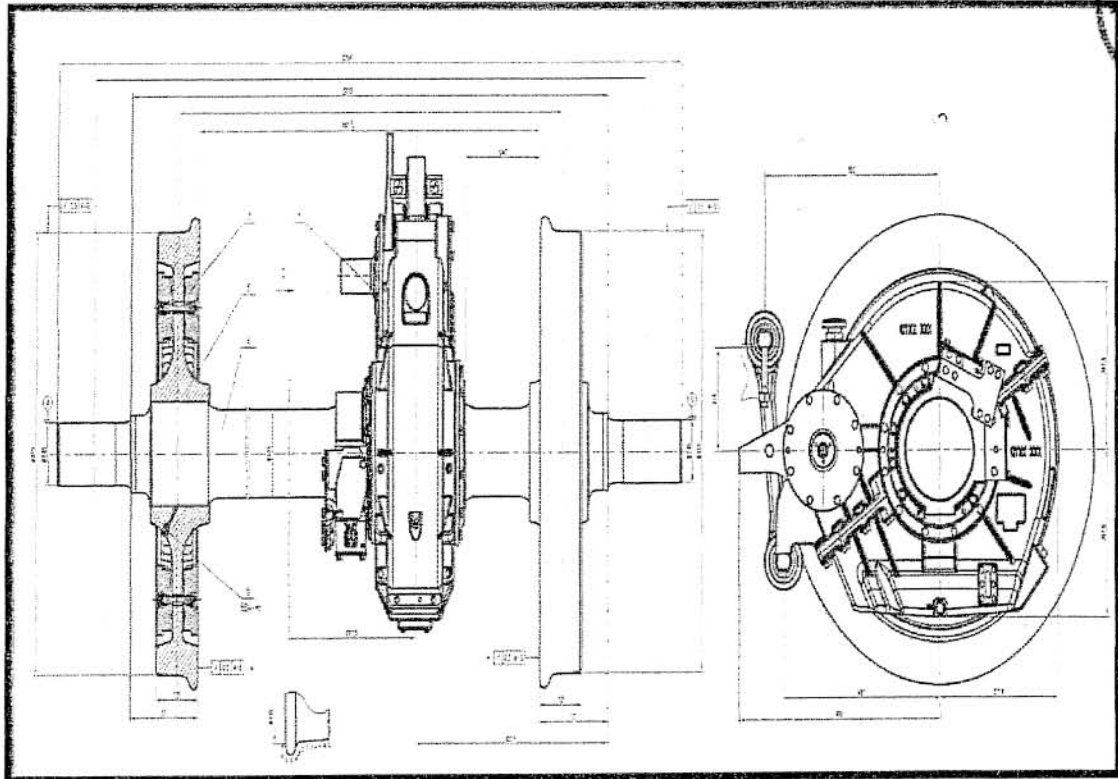
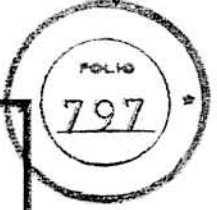

F2 Conjunto de juegos de ruedas

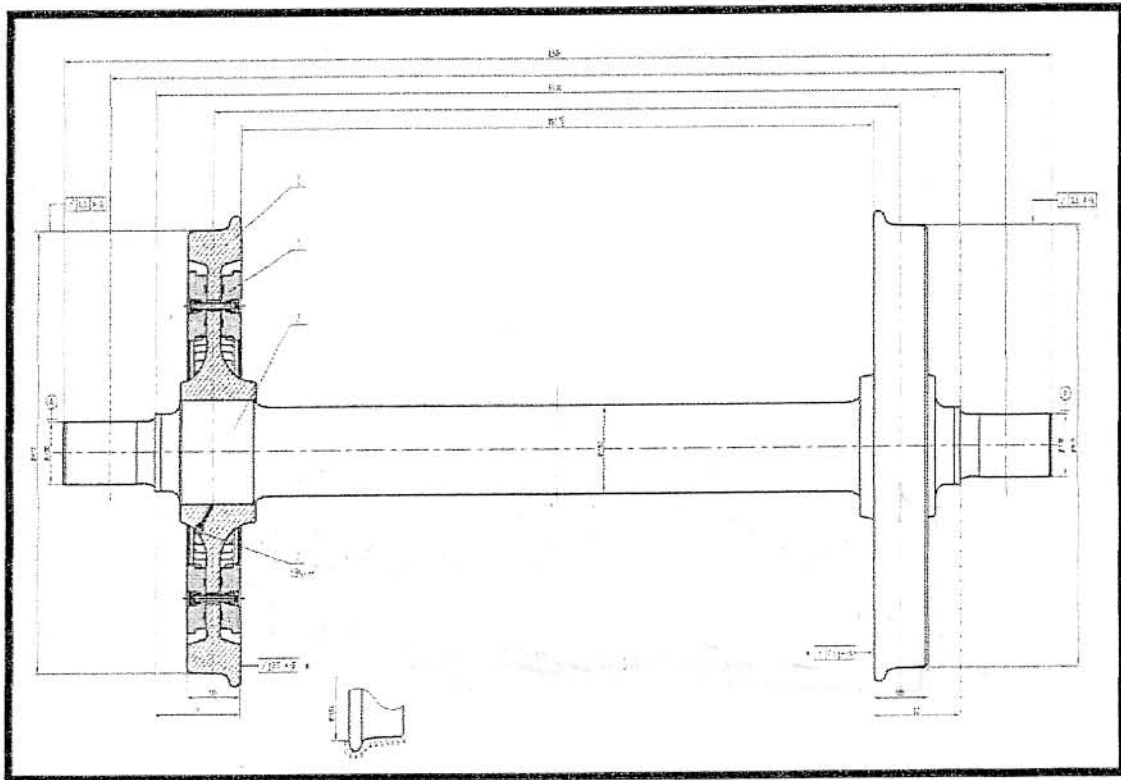



0044

F3 Palanca de ajuste de válvula de nivelación

FOLIO
798

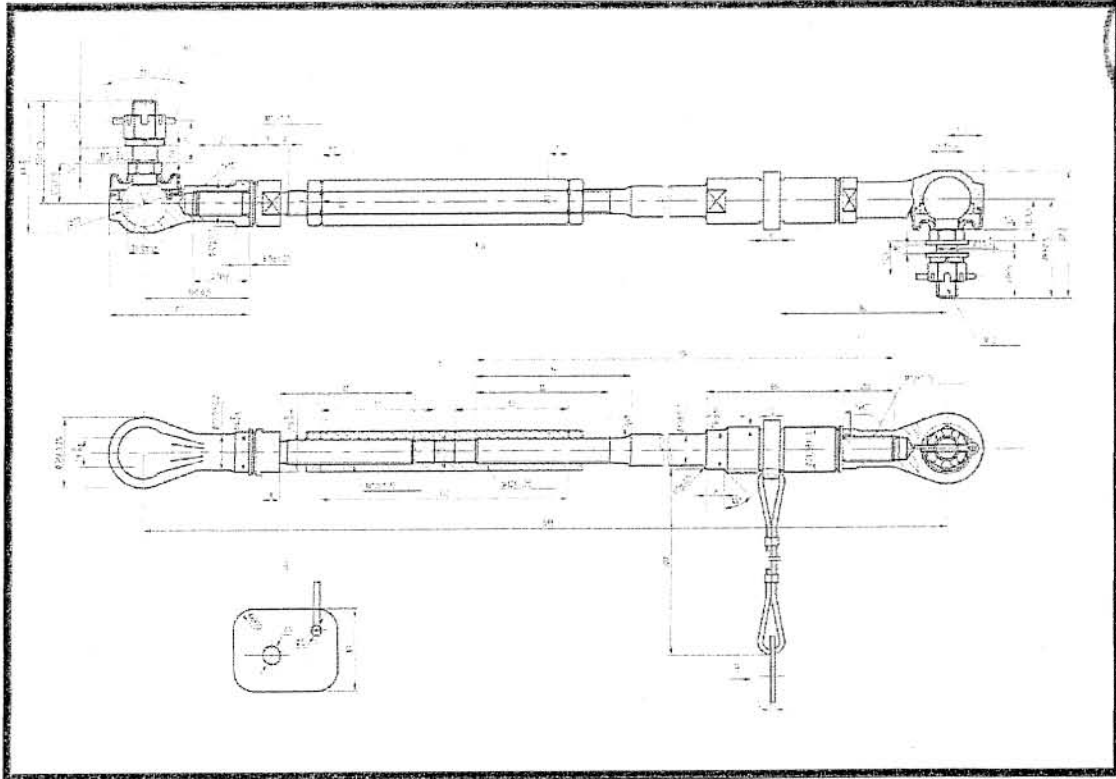

F4 Válvula de presión diferencial izquierda

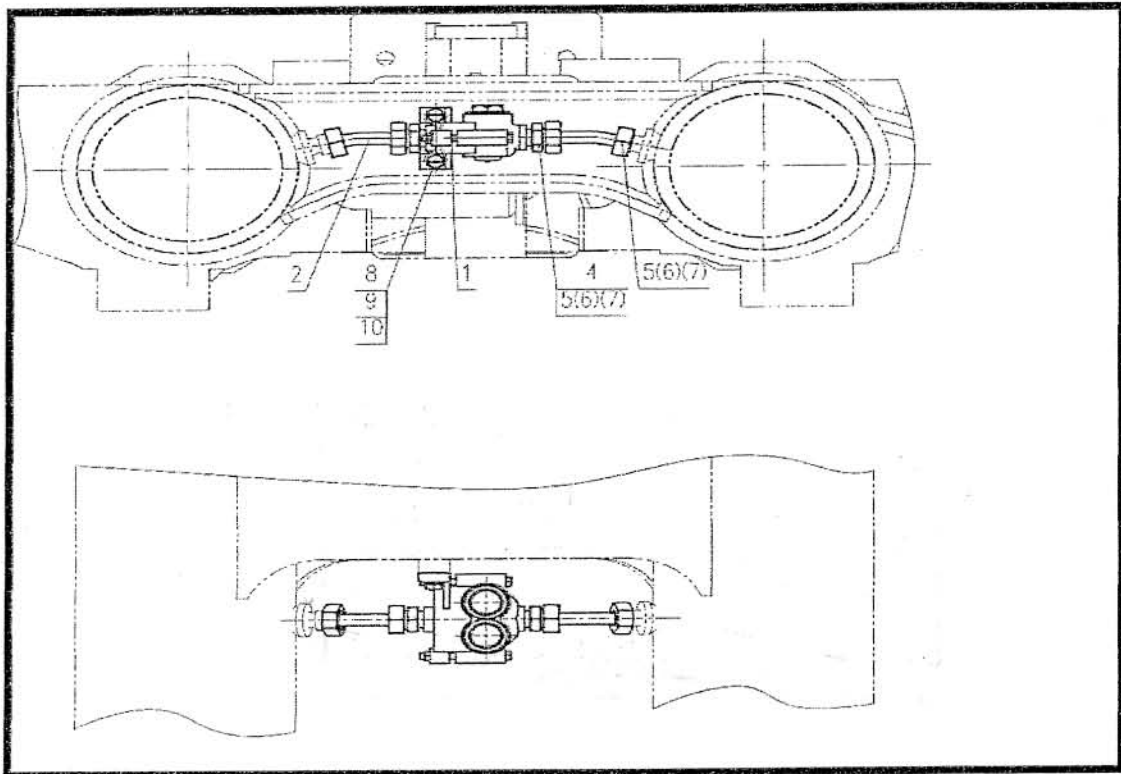



0044

F5 Resorte de acero de doble hélice

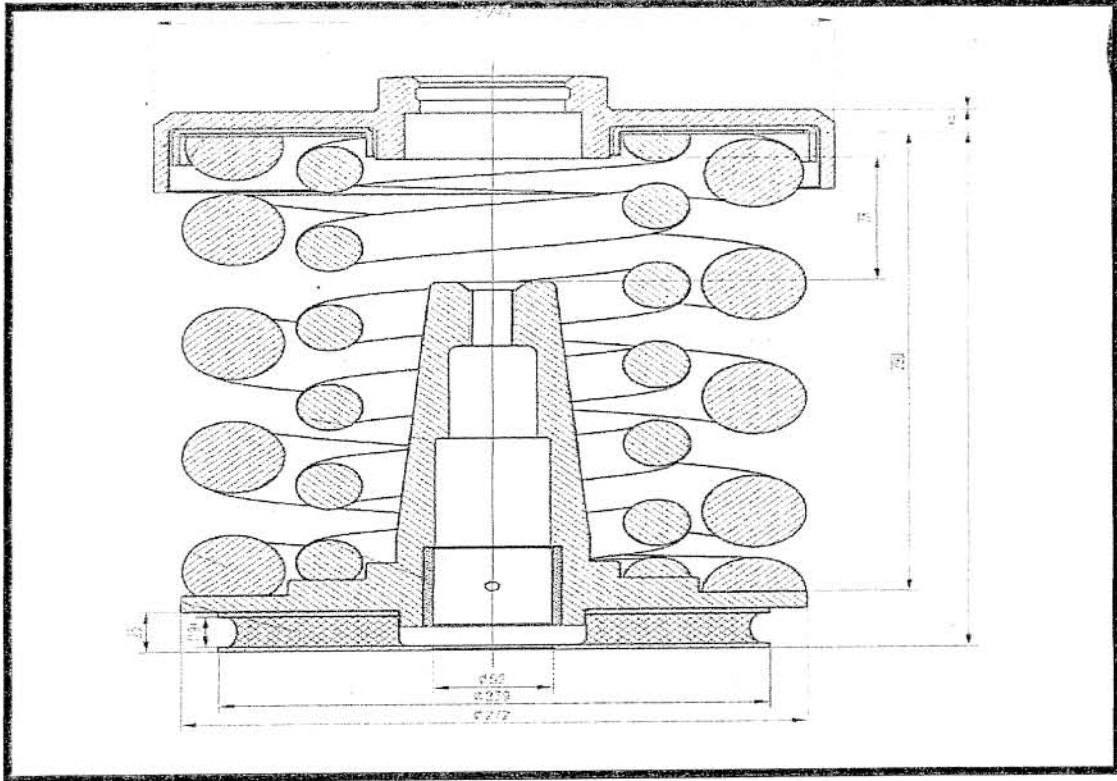
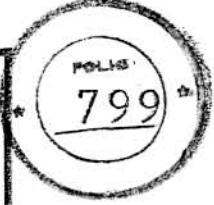

F6 Rodamiento de caja de eje

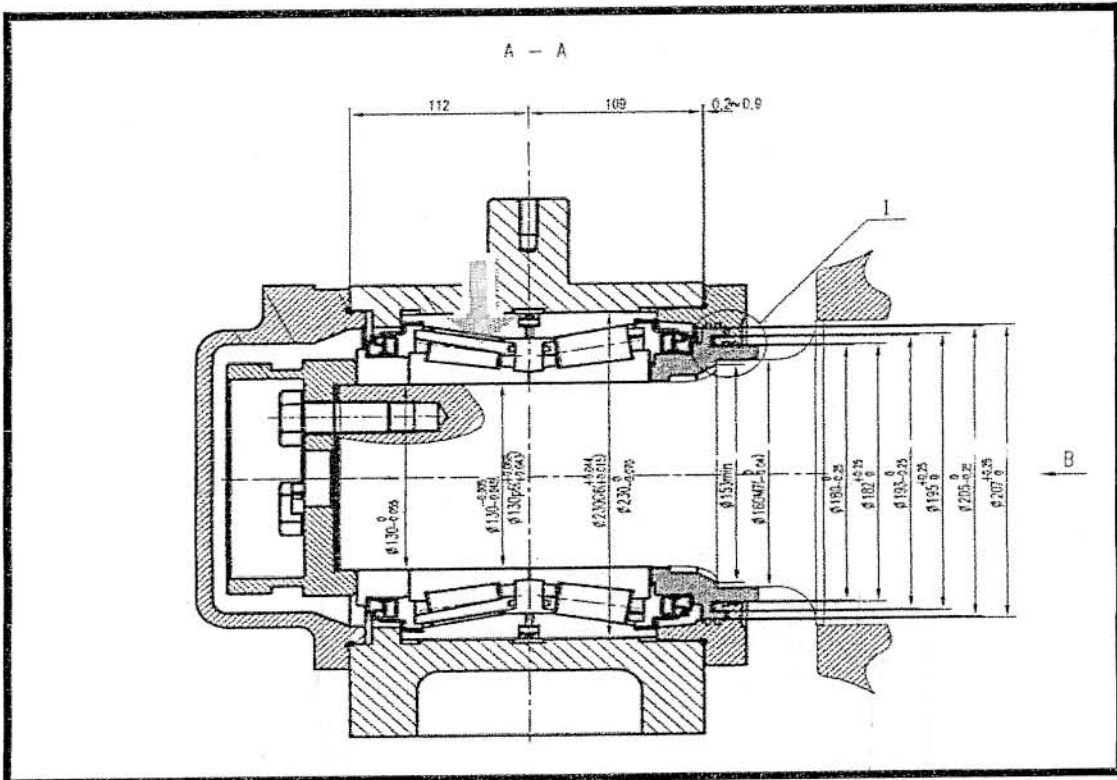



0044

F7 Resorte de aire

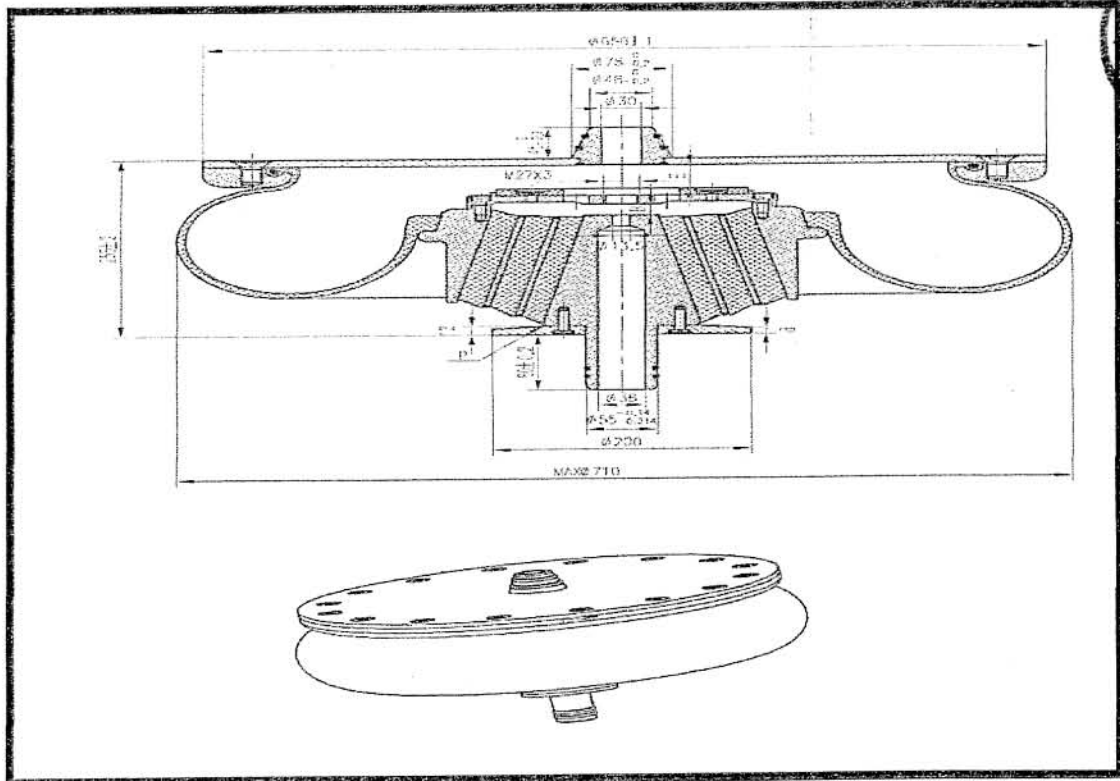

F8 Tope de paragolpes lateral

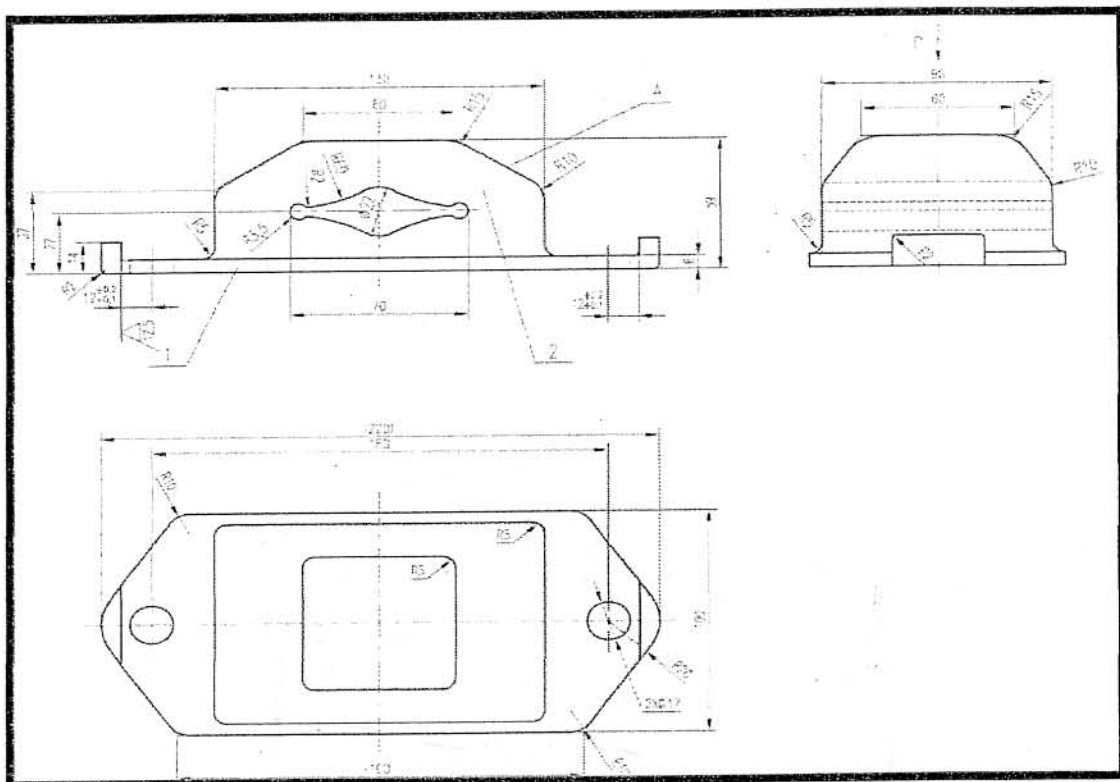



0044

F9 Conjunto de barra de tracción

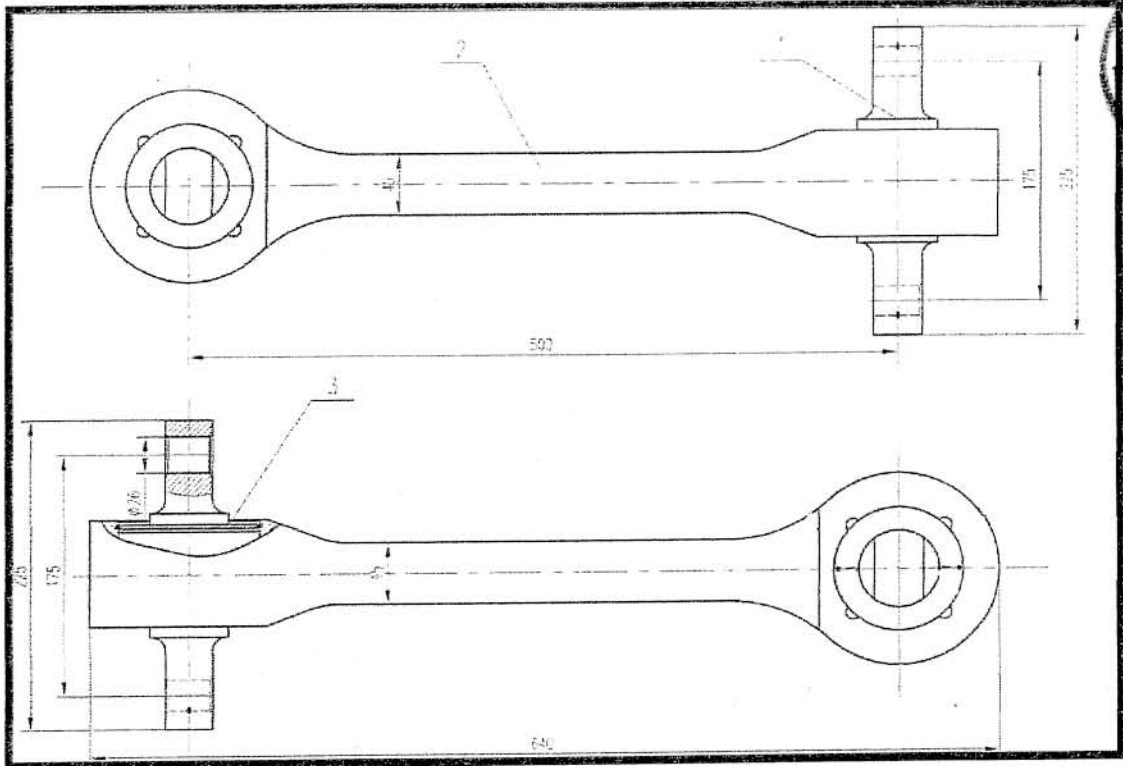

F10 Dispositivo de lubricación de brida de rueda (derecha)

